

RT SERIES

ROUGH TERRAINS SCISSOR LIFTS



Performance

Platform Height—Elevated

3394RT	10.06 m	33 ft
4394RT	13.11 m	43 ft
530LRT	16.2 m	53 ft

Platform Capacity

3394RT	1,020 kg	2,250 lb
4394RT/530LRT	680 kg	1,500 lb

Capacity on Platform Extension

	227 kg	500 lb
--	--------	--------

Capacity with Dual Extensions

3394RT	907 kg	2,000 lb
4394RT	567 kg	1,250 lb
530LRT	680 kg	1,500 lb

Lift/Lower Time

3394RT	30/30 seconds
4394RT	40/43 seconds
530LRT	59/55 seconds

Maximum Drive Height

3394RT/4394RT	Full Height	
530LRT	9.75 m	32 ft

Weight w/One Extension*

3394RT	5,402 kg	11,910 lb
4394RT	6,940 kg	15,300 lb
530LRT	7,711 kg	17,000 lb

Ground Bearing Pressure

3394RT	51 kg/cm²	73 psi
4394RT	5.8 kg/cm ²	83 psi
530LRT	6.3 kg/cm ²	90 psi

Drive Speed

3394RT/4394RT	6.4 km/h	4.0 mph
530LRT	5.6 km/h	3.5 mph

Gradeability

3394RT/4394RT	45%
530LRT	40%

Turning Radius (Inside)

3394RT/4394RT	2.71 m	8 ft 10.5 in.
530LRT	2.72 m	8 ft 11 in.

Turning Radius (Outside)

3394RT/4394RT	5.93 m	19 ft 5.5 in.
530LRT	5.92 m	19 ft 5 in.

* Certain options or country standards will increase weight.

Standard Specifications

Engine

Make and Model

Dual Fuel (Water-Cooled)	
3394RT/4394RT	GM Vortec 3000 MPFI 61 kW 82 hp
530LRT	Kubota WG972 21.6 kW 29 hp

Diesel Fuel (Air-Cooled)

3394RT/4394RT	Deutz D2011L03 36.4 kW 48.8 hp
530LRT	Kubota D1305 18.5 kW 24.8 hp

Fuel Tank Capacity

3394RT/4394RT	113.56 L	30 gal.
530LRT	83.3 L	22 gal.



Tires

Standard	
3394RT/4394RT	33 x 15.5 Superwide
530LRT	12 x 16.5 Foam-Filled

Brakes

- 4 Wheel Spring Applied

Hydraulic Reservoir

- Capacity 121.42 L 32 gal.

Standard Features

- 4-Wheel Drive
- Automatic Transmission
- Three-Speed Drive Select
- Proportional Drive/Lift Up/Lift Down
- Oscillating Axle
- 218 x 3.81 m (86 x 150 in.) Platform²
- 1.22 m (4 ft) Manual Deck Extension
- Aluminum Deck with Grip Strips²
- 110V-AC Receptacle in Platform
- 1.87 x 3.96 m (73.5 x 156 in.) All-Steel Platform³
- Adjustable, Removable Platform Control Station
- On-Board Diagnostics at Platform and Ground Control²
- Fuel Gauge in Platform²
- Fold-Down Handrails
- Horn
- Tilt Light and Alarm
- Manual Descent²
- All Motion Alarm

Accessories & Options

- Leveling Jacks¹
- Dual Extension Deck³
- 3,500 Watt Generator²
- Platform Worklights
- 1.27 cm (1/2 in.) Airline to Platform
- Self-Closing Entry Gates¹
- Flashing Amber Beacon
- 19.7 kg (43.5 lb) Propane Tank
- Cold Weather Start Kit
- 7,500 Watt Generator
- 4,000 Watt Generator³
- Night Bright[®] Package
- Pipe Rack Accessory

1. Standard on 530LRT
 2. Not available on 530LRT
 3. Only available on 530LRT

RT SERIES

ROUGH TERRAINS SCISSOR LIFTS



Dimensions

All dimensions are approximate.

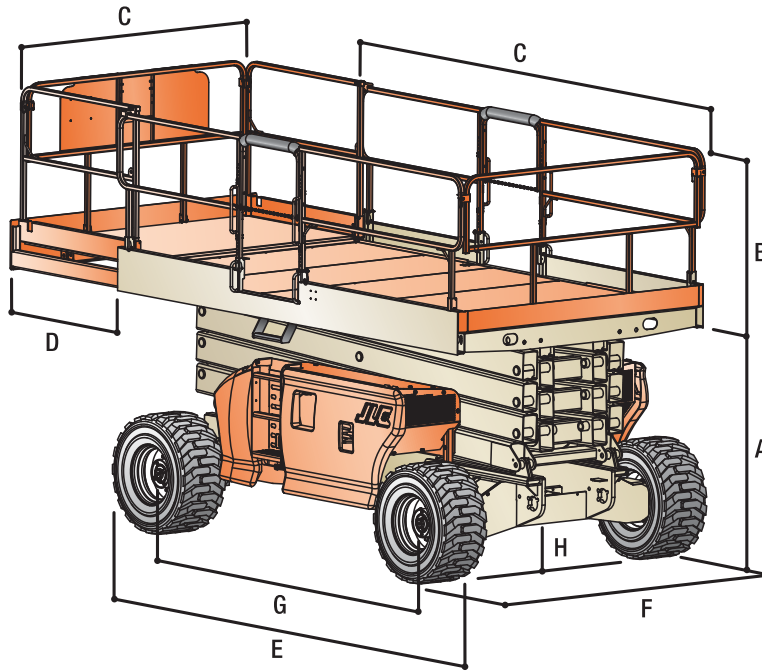

Platform Height — Elevated

3394RT	10.06 m	33 ft
4394RT	13.11 m	43 ft
530LRT	16.2 m	53 ft

A. Platform Height – Lowered

3394RT	1.57 m	5 ft 1.75 in.
4394RT	1.79 m	5 ft 10.4 in.
530LRT	2.13 m	7 ft

B. Platform Railing Height

3394RT/4394RT	1.1 m	3 ft 7.5 in.
530LRT	0.94 m	3 ft 1 in.

C. Platform Size

3394RT/4394RT	2.18 x 3.81 m	86 x 150 in.
530LRT	1.87 x 3.96 m	73.5 x 156 in.

D. Platform Extension

1.22 m	4 ft
--------	------

E. Overall Length

3394RT/4394RT	3.86 m	12 ft 8 in.
530LRT	5.18 m	17 ft

F. Overall Width

3394RT/4394RT	2.39 m	7 ft 10 in.
530LRT	2.31 m	7 ft 7 in.

G. Wheelbase

3394RT/4394RT	2.95 m	9 ft 8 in.
530LRT	2.97 m	9 ft 9 in.

H. Ground Clearance

30 cm	12 in.
-------	--------

The JLG "1 & 5" Warranty

JLG Industries, Inc. backs its products with its exclusive "1 & 5" Warranty. We provide coverage on all products for one (1) full year, and cover all specified major structural components for five (5) years. Due to continuous product improvements, we reserve the right to make specification and/or equipment changes without prior notification. This machine meets or exceeds applicable OSHA Regulations in 29 CFR 1910.67, 29 CFR 1926.453, ANSI A92.5-2006, and CSA Standard CAN3-B354.2-M82, as originally manufactured for intended applications.

Part No.: 3131581
R011608
Printed in USA



JLG Industries, Inc.

1 JLG Drive
McConnellsburg, PA 17233-9533
Telephone 717-485-5161
Toll-free in US 877-JLG-LIFT
Fax 717-485-6417
www.jlg.com

An Oshkosh Corporation Company